

# REEVES<sup>®</sup> AIRTROL<sup>™</sup> for REEVES<sup>®</sup> MOTODRIVE<sup>™</sup>

## INSTALLATION, OPERATION AND MAINTENANCE

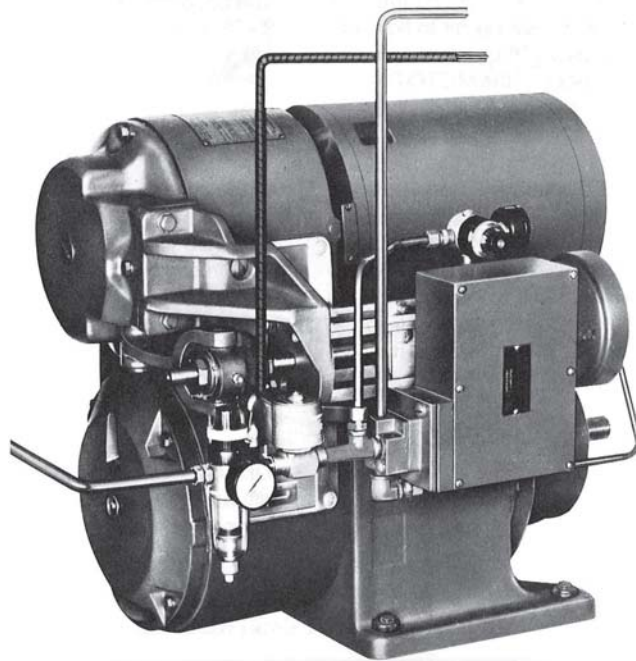

WARNING: Because of the possible danger to person(s) or property which may result from improper use of products, it is important that correct procedures be followed. Products must be used in accordance with the Engineering information specified in the catalog. Proper installation, operation and maintenance procedures must be observed. The instructions in the instruction manuals must be followed. Inspections should be made as necessary to assure safe operation under prevailing conditions. Proper guards and other suitable safety devices or procedures as may be desirable or as may be specified in safety codes should be provided, and are neither provided by Master Power Transmission nor are the responsibility of Master Power Transmission. This unit and its associated equipment must be installed, adjusted and maintained by qualified personnel who are familiar with the construction and operation of all the equipment in the system and the potential hazards involved. When risk to persons or property may be involved, a failsafe device must be an integral part of the driven equipment beyond the speed reducer output shaft.



3300 Tenth St. / Columbus, IN 47201 / (812) 376-1100  
[www.master-pt.com](http://www.master-pt.com)

---

## OPERATION OF THE REEVES AIRTROL

A REEVES AIRTROL is a position type control. A short explanation of its principal features will enable the operation of this control to be understood.

The positioner is the main controlling feature. It has a bellows unit which employs the principle of balanced operation by spring loading the unit to the same force as that exerted by the control instrument air pressure. This unit is connected to a pilot valve. When the control instrument air pressure is increased, the bellows will move against the balance spring. This opens the pilot valve in the direction to allow the supply air to flow into the back of the cylinder, pushing the piston forward, which increases the output speed of the MOTO DRIVE. As the piston moves forward, the cam, which is mounted on the piston rod, moves the positioning lever out. This compresses the balance spring through the slider assembly and bellows lever assembly. The piston will move forward until the balance spring is compressed to give sufficient spring load to balance the increased control instrument air pressure. When this balance is obtained, the bellows will move back to neutral position and close the pilot valve. This stops the supply air flow to the back of the cylinder and the piston will stop moving.

When the control instrument air pressure is decreased the operation is reversed. The control instrument air pressure is lower than the balance spring pressure. This allows the balance spring to move the bellows in the opposite direction, which opens the pilot valve to allow air to escape from the back of the cylinder. The back air

pressure and the force of the belt on the adjusting disc will cause the piston to move back, which will decrease the output speed of the MOTO DRIVE. As the cam moves with the piston rod, it allows the positioning lever to move in, decompressing the balance spring. The piston will move until the balance spring pressure balances the control instrument air pressure. The bellows will assume the neutral position closing the pilot valve and stopping the piston.

The positioner is furnished to operate over the range of 3 - 15 psi control instrument air pressure. By setting the movement on the slider assembly, the piston will move the required amount to obtain the desired output speeds when the control instrument air pressure is operated over the 3 - 15 psi range. Positioners are usually designed to obtain a piston movement in direct proportion to the change in control instrument air pressure. However, in a two-sheave variable speed drive, such as the REEVES MOTO DRIVE, the change in output RPM is not directly proportional to the movement of the adjusting disc. A cam, designed to obtain output RPM change directly proportional to control instrument air pressure change, is mounted on the piston rod to actuate the positioning lever.

The REEVES AIRTROL is fully adjusted and tested before leaving the factory when supplied on new MOTO DRIVE units. The positioner is adjusted to obtain high speed at 15 psi control instrument air pressure and low speed at 3 psi.

## INSTALLATION INSTRUCTIONS

1. On most MOTO DRIVE assemblies the supply air filter-regulator (AP4) is installed on the AIRTROL control at the factory. Install a 1/4" pipe nipple and shut-off valve in the input side of the filter-regulator. Connect the factory air to the shut-off valve. The factory air pressure can be between 80 and 250 p.s.i.g.
2. On those MOTO DRIVE assemblies where the supply air filter-regulator (AP4) is not installed on the AIRTROL control, install the filter-regulator as close to the REEVES drive as possible, and connect the input side of the filter-regulator as in step 1. Connect the output side of the filter-regulator to the input of the solenoid valve (AP65) mounted on the tee connection marked "Supply" on the AIRTROL positioner (AP2) with scale free piping such as 1/4" or 5/16" O.D. copper tubing.
3. Turn on factory air to the filter-regulator (AP4). Adjust the output air pressure of the filter-regulator to give air supply pressure readings on Gauge (APR21) as follows:

MOTO DRIVE Size	Supply Air PSIG
#100	40
#200	40
#300	60
#400	60
#500	60
#600	60
4. Connect the air line from the output of the pneumatic instrument controller to the instrument connection, marked "Inst." on the Positioner (AP2). Any scale-free piping may be used for the connection, however, 1/4" O.D. copper or plastic tubing is recommended.

## AIRTROL CONTROL INSTALLATION

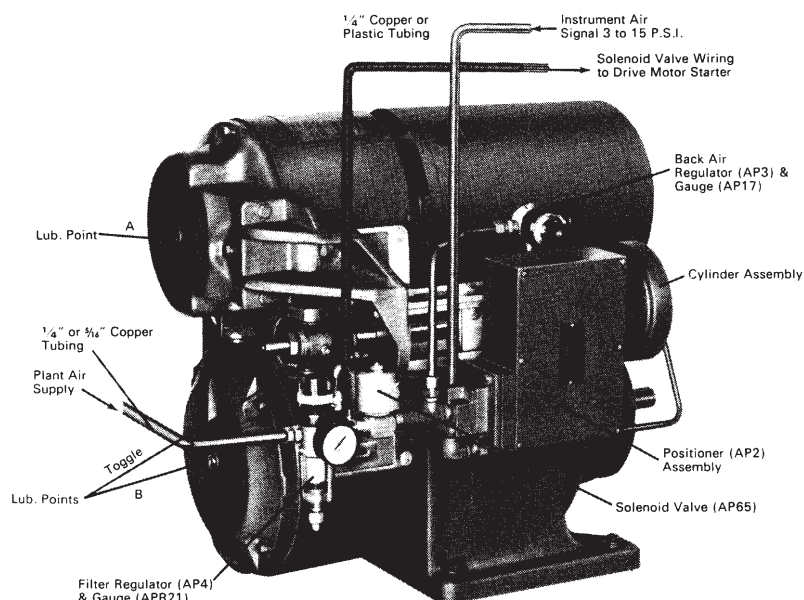

**NOTE:** Lubricate toggle same as points (A) and (B) per Installation & Maintenance Manual.

The REEVES AIRTROL with MOTO DRIVE consists of five items:

1. Filter-Regulator (AP4) and Gauge (APR21)
2. Solenoid Valve (AP65)
3. Positioner (AP2)
4. Back Pressure Regulator (AP3) and Gauge (AP17)
5. Cylinder Assembly

The customer need only make the necessary air and electrical connections and the AIRTROL control is ready for operation.

**NOTE:** For normal operation of the AIRTROL control, the in-plant air supply should deliver 2 CFM at 80 PSIG.

5. Electrically connect the coil of the Solenoid Valve (AP65) in parallel with the drive motor on the REEVES MOTO DRIVE. This connection can be made at the motor or at the motor starter. The Solenoid Valve shuts off the supply air when the drive motor is stopped. This prevents the AIRTROL unit from operating when the MOTO DRIVE is not in operation.
6. Both top side and bottom side loading on the air Cylinder is adjusted at factory.

In order to avoid damage to the MOTO DRIVE belt,

these loading pressures should not be changed.

**CAUTION:** Care should be observed in making the air connections to the Positioner (AP2) on the AIRTROL control so that the supply air is not connected to the instrument connection. If this should happen, the small bellows inside the positioner will be damaged beyond further use. Pipe seal should be applied sparingly to male fittings only. All air connections should be checked for leaks with a suds solution. Carbona Soapless Lather is suggested for this test.

## AIRTROL MAINTENANCE

The REEVES AIRTROL unit is pre-lubricated. The air Filter supplied with the unit will assure clean, dry, oil-free air to the control. As long as this condition is maintained, the control will require no further servicing. Corning #44 grease is used on the "O" Ring (AP45). However, should impurities enter the control, it may necessitate cleaning the small pilot Valve (APV16), located inside the bellows-balance spring element and the air Cylinder (AP47).

The filter-regulator (AP4) has an automatic drain that drains moisture and other contaminants from the filter bowl. The filter-regulator should always be mounted in a vertical position for the automatic drain to operate properly. If the automatic drain does not operate properly, unscrew the filter bowl and check the automatic drain valve assembly for free movement. Clean the valve if it is sticking.

## MOTO DRIVE LUBRICATION

For complete lubrication on the MOTO DRIVE unit, refer to the Installation and Maintenance Manual which is supplied with each unit.

**NOTE:** 400-500-600 size only—These MOTO DRIVE

units have an additional lubrication point for the purpose of lubricating the thrust bearing (43). These should be lubricated every 2 months with a good grade No. 1 NLGI lubricant. Refer to item 79 of the parts list of this manual for location.

## HOW TO REMOVE AND INSTALL V-BELT NO. 100 TO 600 MOTO DRIVE WITH AIRTROL UNIT

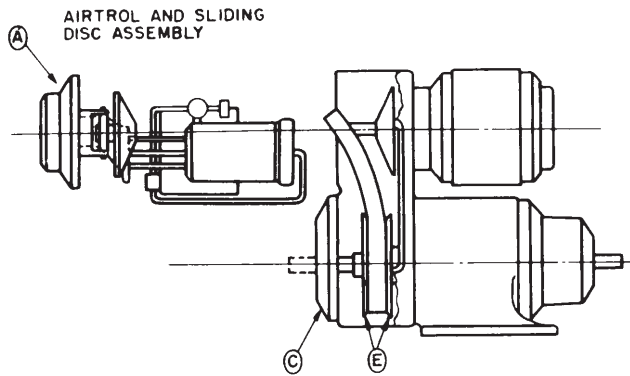

Diagram No. 1

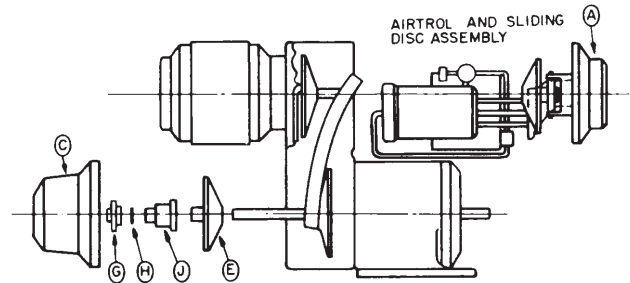

Diagram No. 2

1. Shift the MOTOR DRIVE unit to low speed position.
  2. Disconnect electrical service to unit.
  3. Shut off supply air and control instrument air.
  4. Remove inspection plates from the sides of the MOTOR DRIVE Case.
  5. Disconnect supply and control instrument air lines and Solenoid Valve electrical line so that the AIR-TROL control can be removed from the MOTO DRIVE unit.
  6. Remove four cap screws holding control cover "A" to MOTO DRIVE Case and remove complete control and sliding disc assembly from MOTO DRIVE unit.
  7. Pull upper loop of the belt over the end of the fixed motor disc hub.
  8. Remove variable shaft bearing plate "C" after belt is freed from disc hub.
- \* 9A. ("C" flow style or alternate "Z" flow style MOTO DRIVE assembly numbers 100-A, 100-AL, 100-AR, 111-A and 112-A, see diagram No. 1.) Free the belt from the variable discs "E" and remove from case.
- 9B. ("Z" flow style MOTO DRIVE, see diagram No. 2.) Remove the following parts from the variable shaft: collar and bearing "G"; retaining ring "H"; spring and cartridge assembly "J"; and sliding disc "E." Remove old belt from the case.
- \*10A. ("C" flow style or alternate "Z" flow style MOTO DRIVE, see diagram No. 1.) Place the new belt into the case, positioned loosely around the variable speed discs "E" and replace bearing plate "C."
- 10B. ("Z" flow style MOTO DRIVE, see diagram No. 2.) Place the new belt into the case, positioned loosely around the variable shaft and replace sliding disc "E"; spring and cartridge assembly "J"; retaining ring "H"; collar and bearing "G"; and bearing plate "C."
11. Spread the variable speed discs "E" and position the belt between the discs, deep enough to secure slack; then loop the belt over the fixed motor disc hub.
  12. Replace complete control and sliding disc assembly "A."
  13. Connect supply and control instrument air lines to the AIRTROL control and turn on supply and control instrument air. Connect electrical line to Solenoid Valve.
  14. Replace inspection plate on side of MOTO DRIVE Case.
  15. Lubricate and place in service.
- \*Applies to the number 100 MOTO DRIVE units for all assemblies.

### ADJUSTMENT OF THE AIRTROL UNIT

The cam (AP8) must be in proper relation to the belt in order for the control to function properly. If it becomes necessary to disassemble the control, the following adjustment procedure should be followed after the control is reassembled:

1. Make sure the roll pin (AP60) through the cam block (AP9) and piston rod (AP6) is in place.
2. **IMPORTANT**—Make initial setting of low speed and high speed stops (27, 28) according to dimensions "L" and "H."

- For size Nos. 100, 200 and 300 MOTO DRIVE units only, place a  $\frac{3}{16}$ " spacer between the boss on the cylinder and the cam. For size Nos. 400 thru 600, 40 H.P., MOTO DRIVE units only, place a  $1\frac{1}{2}$ " spacer between the boss on the cylinder and the cam. For size No. 600K (50 H.P.) MOTO DRIVE unit only, place a 2" spacer between the boss on the cylinder and the cam. Slide the piston rod into the cylinder until the cam rests against the spacer. (The low speed stop (27), as set in Step 2, may strike the control bracket (AP20) before the cam rests against the spacer. Readjust the low speed stop (27) if necessary.)
- Start the MOTO DRIVE unit—but do not turn on the supply air. Loosen jam nuts and adjust the toggle (AP22) position on the piston rod by turning the piston rod toggle nut (AP27) until the variable shaft low speed as shown on chart below is obtained. This will locate the cam in proper relation to the belt. (NOTE: On a MOTOR DRIVE with a reducer, the variable shaft is the input shaft to the reducer.)
- Turn on the supply air and control instrument air. Check the supply air pressure (AP4) and back air pressure (AP3). Adjust to the required pressures listed on chart below.
- Set the control instrument air pressure at 3 psi. Adjust the spring (APV13) in the positioner (AP2), by turning the knurled nut on the spring retaining assembly (APV12), until the minimum speed as shown on the MOTO DRIVE nameplate is obtained

on the output shaft. Tighten the lock nut on the spring retaining assembly.

- Turn the low speed stop (27) until it is  $\frac{1}{64}$ " from the control bracket (AP20). Lock with the jam nut.
- Set the control instrument air pressure at 15 psi. Check the output speed. This speed should be the maximum speed as shown on the MOTO DRIVE nameplate. If the speed is too high, the stroke setting is too long. If the speed is too low, the stroke setting is too short. Readjust the stroke setting in the positioner (AP2) by loosening the slider pinion screw (APV11) and turning the slider screw (APV10). Tighten the pinion screw. (The high speed stop (28), as set in Step 2, may strike the control bracket (AP20) before maximum speed is obtained. Readjust the high speed stop (28) if necessary.)
- Repeat Steps 6 and 8 until the required minimum and maximum speeds are obtained when the control instrument air pressure is set at 3 psi and 15 psi. Each time the slider screw or stroke is adjusted, the spring adjustment also changes.
- Set the control instrument air pressure at 15 psi. Turn the high speed stop (28) until it is  $\frac{1}{64}$ " from the control bracket (AP20). Lock with the jam nut.
- Check moving parts for possible binding as the MOTO DRIVE unit is shifting through the speed range. The AIRTROL control should now be properly adjusted and ready for operation.

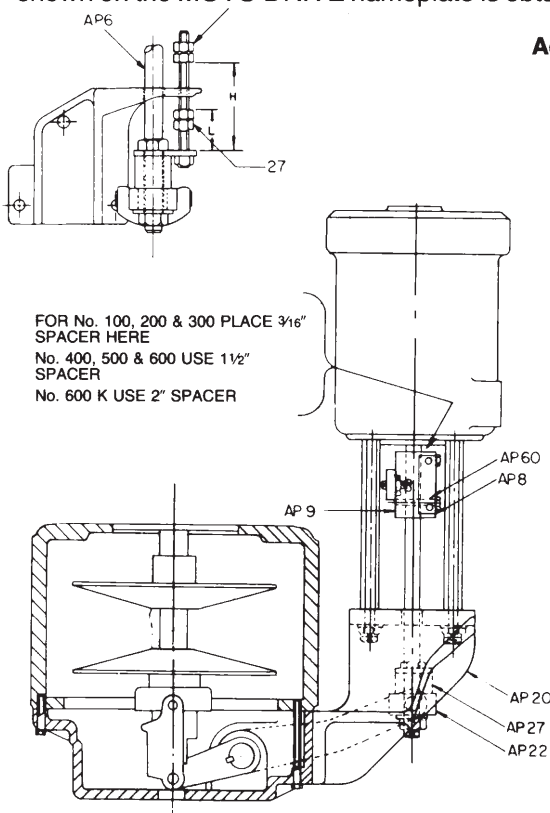

### Adjustment Settings

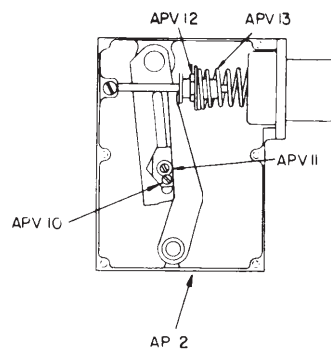

27 STOP, MIN. SPEED

- 27 STOP, MIN. SPEED
- 28 STOP, MAX. SPEED
- AP2 ASSEMBLY, POSITIONER
- AP6 ROD, AIR PISTON
- AP8 CAM POSITION
- AP9 BLOCK, POSITIONER CAM MOUNTING
- AP20 BRACKET, CONTROL
- AP22 TOGGLE, PISTON ROD
- AP27 NUT, PISTON ROD TOGGLE
- AP60 ROLL PIN
- APV10 SLIDER PINION SCREW
- APV11 SLIDER SCREW
- APV12 SPRING RETAINING ASSEMBLY
- APV13 SPRING (3 TO 15-P.S.I.)

MOTO-DRIVE SIZE	SPEED RANGE (CLASS)	DIM. H	DIM. L	SUPPLY P.S.I.G.	BACK P.S.I.G.	VARIABLE SHAFT LOW SPEED	
						1800 MOTOR	1200 MOTOR
100	M, D, E, F, G	3-7/8	7/8	40	10	466	310
200	D, E, F, G*	4-1/4	7/8	40	10	500	334
200	M	4-9/16	31/32	40	10	420	270
300	D, E, F, G*	4-9/16	7/8	60	20	500	334
300	M	4-23/32	15/16	60	20	420	270
400	M, D, E, F, G	4-13/16	47/64	60	10	500	334
500	M, D, E, F, G	5-15/32	1-29/32	60	10	600	400
600-1	M, D, E, F, G	5-5/8	1-1/2	60	10	630	420
600-2	M, D, E, F, G	5-7/8	1-5/8	60	10	630	420
600K	F, G	5-27/32	2-5/16	60	10	857	

\* USE CLASS "M" SETTINGS FOR ALL #200 AND #300 SIZE MOTODRIVES EQUIPPED WITH MOTOR ADAPTORS (PART #230 SHOWN IN MANUAL G-3014-5).

## PARTS LIST—AIRTROL CYLINDER AND POSITIONER No. 100 — MOTO DRIVE

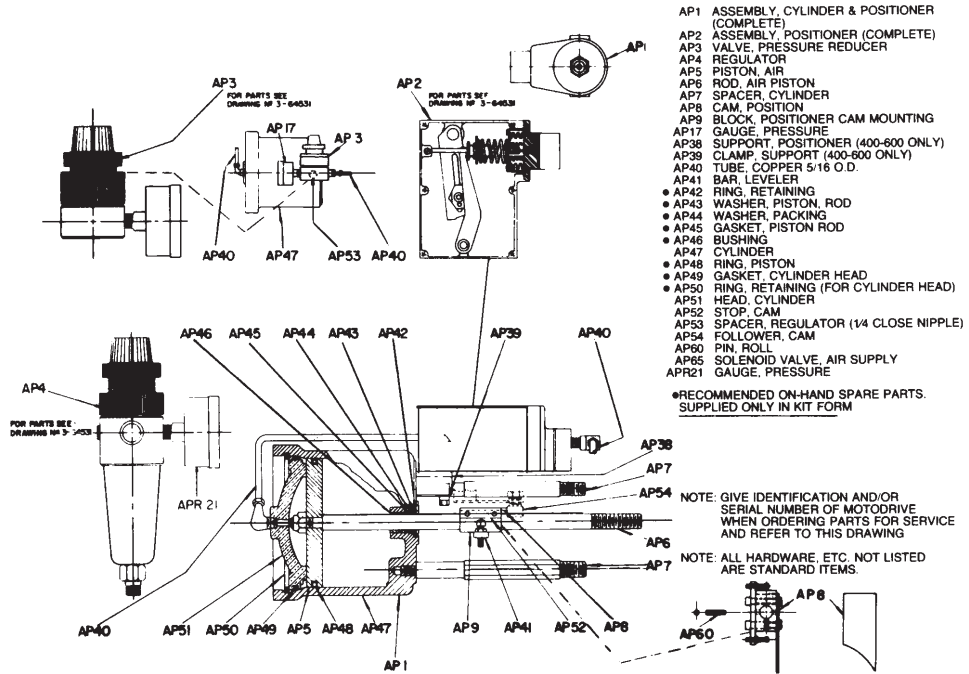

## PARTS LIST—AIRTROL—POSITIONER (AP2) BACK AIR PRESSURE REGULATOR (AP3) SUPPLY AIR REGULATOR FILTER (AP4)

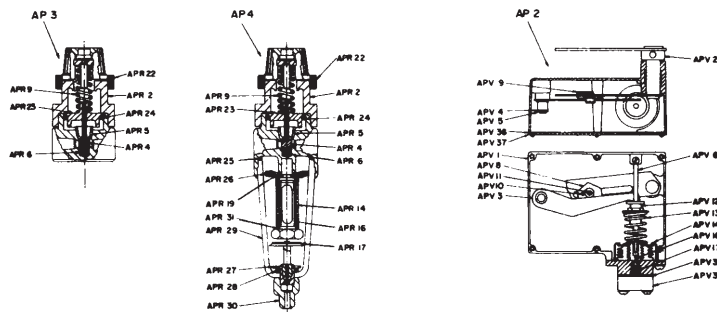

- AP 3 VALVE, PRESSURE REDUCER (COMPLETE)
- APR 2 REGULATOR BONNET
- APR 9 REGULATOR SPRING
- APR 22 ADJUSTING KNOB LOCKNUT
- APR 4 VALVE ASSEMBLY
- APR 5 VALVE SEAT
- APR 6 VALVE SPRING
- APR 23 PISTON
- APR 24 VEE PACKING

REPAIR KIT ONLY

- AP 4 FILTER—REGULATOR (COMPLETE)
- APR 2 REGULATOR BONNET
- APR 9 REGULATOR SPRING
- APR 16 FILTER POST
- APR 26 LOUVER
- APR 29 BOWL
- APR 30 NUT
- APR 22 ADJUSTING KNOB LOCKNUT
- APR 4 VALVE ASSEMBLY
- APR 5 VALVE SEAT
- APR 6 VALVE SPRING
- APR 14 FILTER ELEMENT
- APR 19 GASKET
- APR 25 "O" RING
- APR 31 GASKET
- APR 23 PISTON
- APR 24 VEE PACKING
- APR 17 VALVE ASSEMBLY
- APR 27 INSERT ASSEMBLY
- APR 28 "O" RING

REPAIR KIT ONLY

REPAIR KIT ONLY

- AP 2 POSITIONER ASSEMBLY (COMPLETE)
- APV 1 CASE ASSEMBLY
- APV 2 POSITIONING LEVER ASSEMBLY
- APV 3 BELLOWS LEVER ASSEMBLY
- APV 4 WASHER
- APV 5 EXTERNAL COTTOR
- APV 6 BELLOWS SPRING POST
- APV 8 SLIDER ASSEMBLY
- APV 9 SLIDER PLATE NUT
- APV 10 SLIDER PINION SCREW
- APV 11 SLIDER SCREW
- APV 12 SPRING RETAINING ASSEMBLY
- APV 13 SPRING (3 TO 15 P.S.I.)
- APV 14 BELLOWS ASSY. W/PILOT (COMPLETE)
- APV 16 PILOT VALVE PLUNGER
- APV 17 PILOT VALVE
- APV 31 GASKET
- APV 32 ADAPTOR BLOCK ASSEMBLY
- APV 36 COVER GASKET
- APV 37 COVER

NOTE: GIVE IDENTIFICATION AND/OR SERIAL NUMBER OF MOTODRIVE WHEN ORDERING PARTS FOR SERVICE AND REFER TO THIS DRAWING.

NOTE: ALL SCREWS ETC. NOT LISTED ARE STANDARD ITEMS.

NOTE: FOR COMPLETE CONTROL ASSEMBLY SEE DWG. No. 3-64462 FOR 100-300 3-64463 FOR 400-600

●RECOMMENDED ON HAND SPARE PARTS.

**PARTS LIST—AIRTROL  
No. 100-600 — MOTO DRIVE**

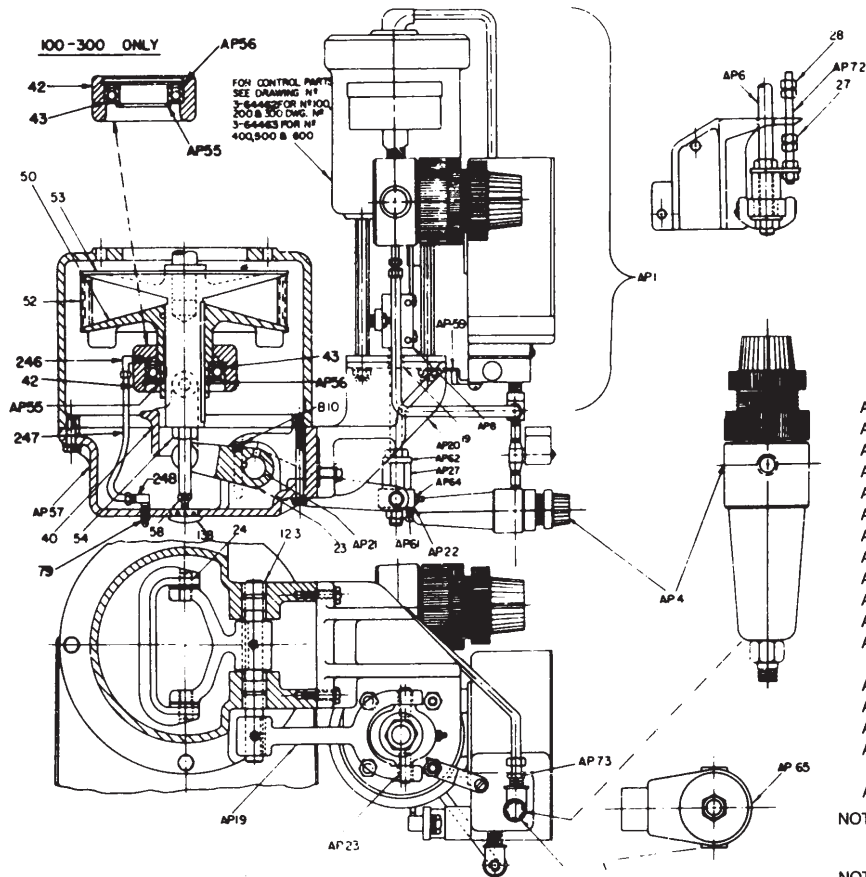

- 19 BUSHING OILITE
- 23 YOKE, SHIFTING
- 24 SCREW, FULCRUM
- 27 STOP, MIN. SPEED
- 28 STOP, MAX. SPEED
- 40 LINK, SHIFTING
- 42 HOUSING, THRUST BRG.
- 43 BEARING, THRUST
- 50 DISC, SLIDING
- 52 BELT
- 53 DISC, FIXED
- 54 ADAPTOR, LUB FITTING (2 TO 600 ONLY)
- 58 FITTING, LUB (ALEMITE)
- 123 BUSHING OILITE
- 138 BUTTON, PLUG
- AP1 ASSEMBLY CYLINDER 8 POSITIONER
- AP4 REGULATOR, FILTER
- AP6 ROD, AIR PISTON
- AP8 CAM, POSITION
- AP19 ARM, SHIFTING
- AP20 BRACKET, RH OR LH
- AP21 SHAFT, SHIFTING ARM
- AP22 TOGGLE, PISTON ROD
- AP23 PIN, TOGGLE
- AP27 NUT, PISTON ROD TOGGLE
- AP55 RING, RET (WALDES)
- AP56 RING, RET (BEARING HOUSING)
- AP57 HOUSING, CONTROL
- AP61 WASHER, PISTON ROD TOGGLE
- AP62 GUIDE STOP
- AP64 LUB FITTING, TOGGLE
- B10 SCREW, LOCKING
- AP65 SOLENOID VALVE, (AIR SUPPLY)
- AP59 BRACKET, POSITIONER SUPPORT
- AP72 STOP SCREW
- AP73 CONNECTOR W/RESTRICTOR (FOR UNIT WITH BRAKE ONLY)
- AP79 BUSHING (SIZES 100, 200 ONLY)

NOTE: GIVE IDENTIFICATION AND/OR SERIAL NUMBER OF MOTODRIVE WHEN ORDERING PARTS FOR SERVICE AND REFER TO THIS DRAWING.

NOTE: ALL HARDWARE, ETC. NOT LISTED ARE STANDARD ITEMS.

